

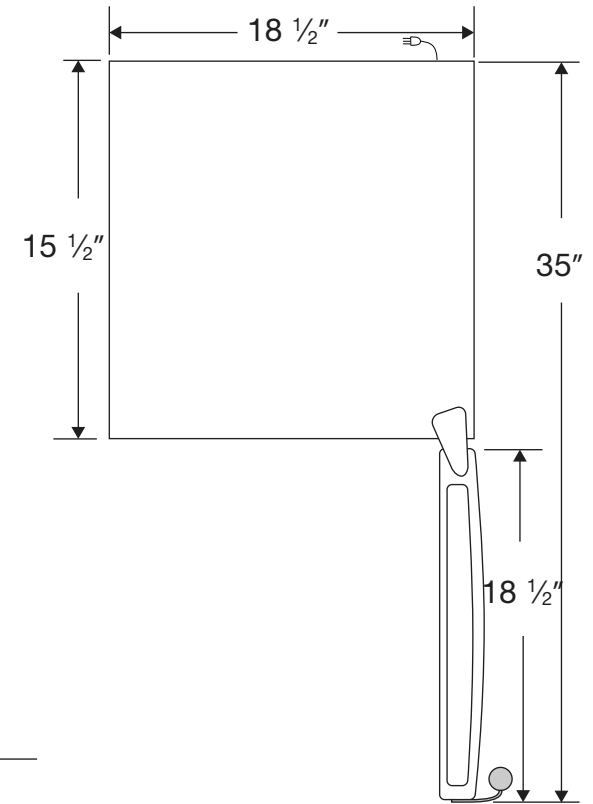

Front View

Side View

Top View

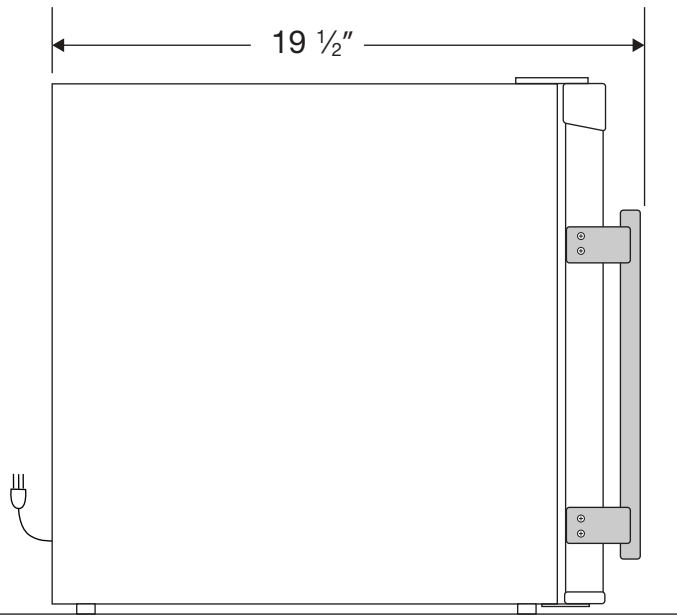
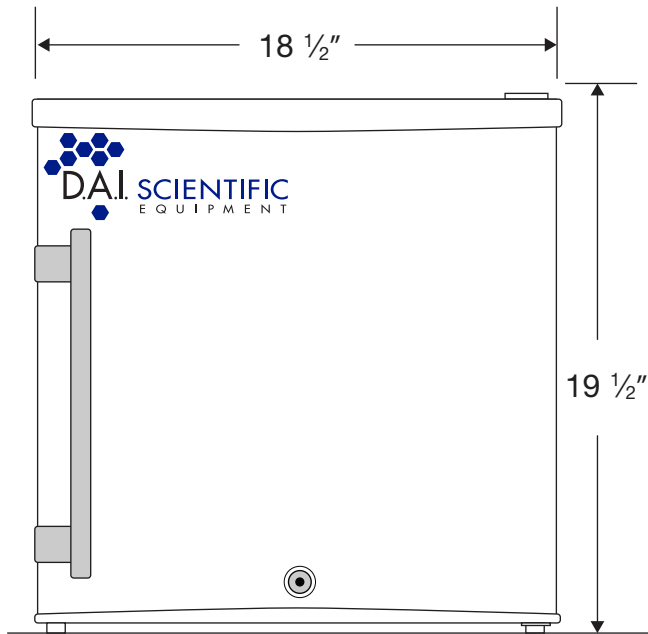

 115VAC/60Hz/1PH  
NEMA-5-15P

Cu. Ft	Defrost	Door	Int Door	Shelves	W"	D"	H"	Refrigerant	H.P.	Amps	Weight
1.5	Manual	1 Solid (Reversible)	0	1 Fixed	18 1/2	19 1/2	19 1/2	R600a	1/10	1.1	46 lbs.