



**Product Data Sheet**

20 Cu. Ft. Basic Series Hazardous Location Manual Defrost Freezer

**DAI-HC-EFP-20**

**Images**



**Product Description**

Hazardous location freezers meet NFPA and OSHA guidelines for Hazardous Location, Class 1, Division II, Groups A,B,C & D guidelines. These units utilize non-sparking and/or ATEX rated components and are engineered for use in environments where volatile/explosive conditions could potentially exist.

Models feature a microprocessor temperature controller, allowing for precise temperature control, recovery and maintenance versus mechanical style thermostats. Our Basic Series freezers run on natural, hydrocarbon refrigerant for environmental health and energy efficiency. For storage of flammable or volatile materials within typical laboratory or non-volatile environments, see Flammable Material Storage units.

**Certifications**



**General Description and Application**

|                                  |  |
|----------------------------------|--|
| Storage capacity (cu. ft)        | 20   |
| Door                             | Right Hinged   |
| Shelves                          | 6 Fixed  |
| Freezer Compartments             | Non-applicable   |
| Baskets                          | Non-applicable   |
| Mounting                         | Leveling Legs  |
| Interior lighting                | Non-applicable   |
| Airflow management               | Non-applicable   |
| External probe access            | Non-applicable   |
| Insulation                       | Cabinet is foamed-in-place with EPA compliant high density urethane foam   |
| Exterior materials               | White powder coated steel  |
| Access Control                   | Keyed door lock  |
| General warranty                 | Two (2) year parts and labor warranty  |
| Warranty Disclaimer              | Products require 4" of clearance around back and sides of the unit for proper ventilation - improper installation will void the warranty and will lead to temperature maintenance issues, overheating and possible failure |
| Product Weight (lbs)             | 225  |
| Shipping Weight (lbs)            | 250  |
| Rated Amperage                   | 5.5 Amps   |
| Power Plug/Power Cord            | Power cord is not included - final power connections at site must be hardwired to meet local codes   |
| Facility Electrical Requirement  | 115V, 60 Hz  |
| Agency Listing and Certification | ETL, C-ETL listed and certified to UL471 standard, hydrocarbon refrigerant safety, Energy Star Certified. Units meet NFPA and OSHA guidelines for Hazardous Location, Class 1, Division II, Groups A,B,C & D guidelines.   |

**Refrigeration System**

|             |        |
|-------------|--------|
| Refrigerant | R290   |
| Defrost     | Manual |

**Controller, Configuration, Alarms and Monitoring**

|                              |   |
|------------------------------|---|
| Controller technology        | Microprocessor temperature controller with digital temperature display, °C/°F switchable  |
| Display technology           | Standard Digital Temperature Display  |
| Adjustable Temperature Range | -15°C to -25°C  |
| External alarm connection    | State switching remote alarm contacts   |
| Alarms                       | Audible and visual high and low temperature alarms  |
| Controller probe             | Non-applicable  |
| Digital Communication        | Non-applicable  |
| Data Transfer                | Non-applicable  |
| Disclaimers                  | Power cord is not included-final power connections at site must be hardwired to meet local codes<br><br>Indoor use only, +18°C to +26°C (+65°F to +78°F), <70% RH<br><br>Defrosting of the unit will need to be performed periodically to prevent severe ice build-up<br><br>Specifications are subject to change |

**Dimensions**

|          | Width (in.) | Depth (in.) | Height (in.)   | Door Swing (in.) | Total open Depth (in.) |
|----------|-------------|-------------|----------------|------------------|------------------------|
| Exterior | 30 3/4"     | 29"         | 74 5/8"        | 28 3/4"          | 57 3/4"                |
| Interior | 25 7/8"     | 21 3/4"     | Non-applicable |                  |                        |

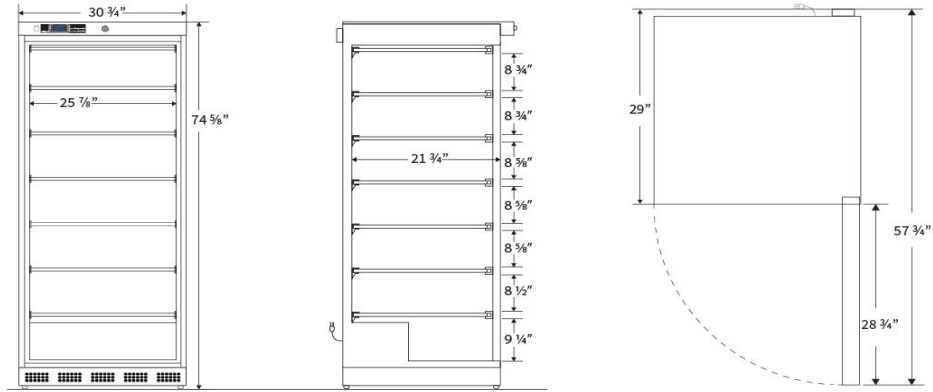

**Contact**

Customer Service

866-705-4749

[customerservice@daiscientific.com](mailto:customerservice@daiscientific.com)